

Separator max. flow: 50 l/s  
 h = inlet distance from ground (default 1500):

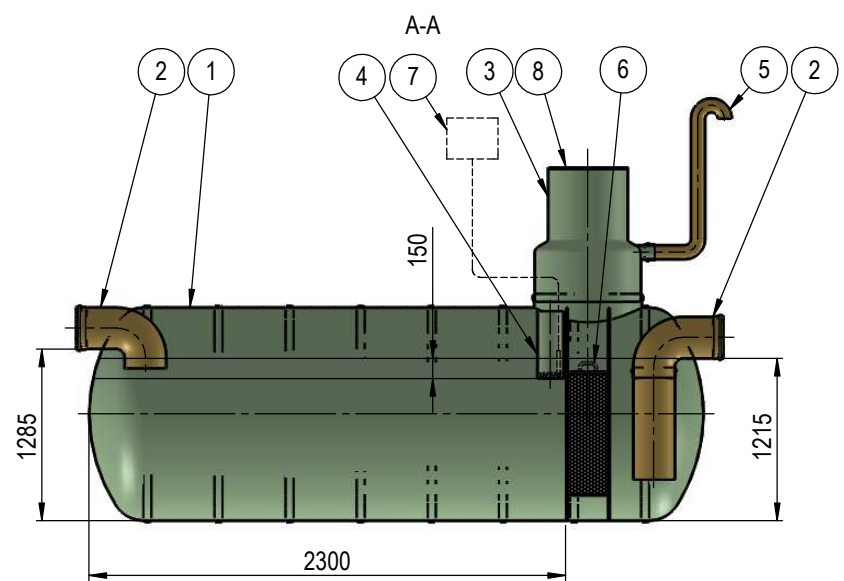

Item	Part	Description	Std. qty.	Need
1	Separator housing	fiberglass, $\varnothing$ 1600 x 4600	1	
2	Inlet-/outlet sewer	DN315	2	
3	Maintenance shaft	$\varnothing$ 800/600	1	
4	Oil removal shaft	$\varnothing$ 200	1	
5	Ventilation outlet	DN110	1	
6	Coalescer block		1	
7	Level alarm device		1	
8	Top cover	plastic	1	
		cast iron		

	<b>Klaasplast OÜ</b> reg.kood: 11862070 tel: +372 5691 1914 info@mahuti.ee www.mahuti.ee	Weight	Date	Drawn by	E. Väljaots
			7.04.2021	Drawing no.	KPO.50.01
Title		I-class oil separator			
Sheet	Scale	Article no.			
1/1	1 : 40	NS50			